

PEQ50-48S Series

50 Watt Quarter Brick

Features

- Industry standard footprint:
2.28" x 1.45" x 0.37"(57.9 x 36.8 x 9.3mm³)
- Typical efficiency: 88%
- Wide input voltage: 36-75V
- Single output: 1.2V, 1.5V, 1.8V
- Remote control
- Trim and sense function
- Input under-voltage shutdown
- Output over-current protection
- Output over-voltage protection
- Output short-circuit protection
- Over-temperature protection
- No minimum load requirement
- Basic isolation

Environmental

- Operating ambient temperature range:
-40 to 55
- Operating board temperature range:
-40 to 100
- Storage temperature:
-55 to 125
- Over-temperature protection:
>120 typical
- Temp.coefficient:
<±0.02%/
- MTBF:
>2 million hrs

Electrical Specifications

Input

Input range: 36-75Vdc
Input under-voltage shutdown: 32-34Vdc

Output

Voltage setpoint accuracy: ±1.5%V_o max.
Voltage adjust: 90% to 110%V_o

Line regulation: 0.2%V_o max.

Load regulation: 0.2%V_o max.

Short-circuit protection: continuous, auto-recovery(or latch off)

Over-current protection: >110%I_o, auto-recovery(or latch off)

Over-voltage protection: >110%V_o, latch off (or auto-recovery)

Ripple and noise: <100mVpp max.

Transient response: recovery <250uS max.
200mV max.
(25% step load change from 50%I_o)
di/dt: 1A/10uS

Control

Control voltage:

Positive logic

High =on 3.5 to 10Vdc

Low=off -0.7 to 1.5Vdc

Negative logic

Low =on -0.7 to 1.5Vdc

High=off 3.5 to 10Vdc

Control current:

2mA max.



Ordering Information

Input Voltage	Output Voltage	Output Current	Efficiency	Model Number
48V	1.2V	30A	85%	PEQ50-48S1V2-4
48V	1.5V	30A	87%	PEQ50-48S1V5-4
48V	1.8V	30A	88%	PEQ50-48S1V8-4

Dimensions

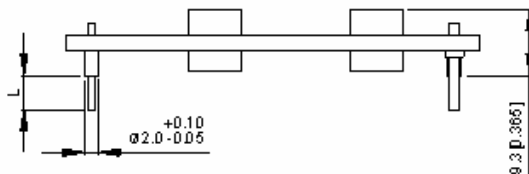
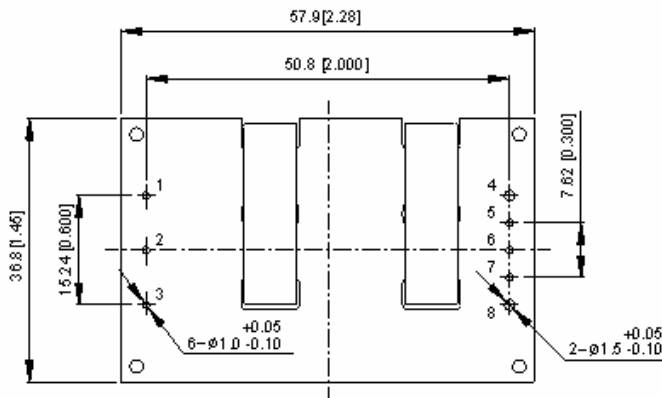

TOLERANCES : X.Xmm=±0.5mm
X.XXmm=±0.25mm

Unit:mm[inch]

Pin Assignments

1. +Vin
2. CNT
3. -Vin
4. +Vo
5. +Sense
6. Trim
7. -Sense
8. -Vo

Pin Length

4.8mm	-4
3.8mm	-6
2.8mm	-8
5.8mm	None

Notes: The detail and recommended hole pattern layout is available in the Application Manual.